

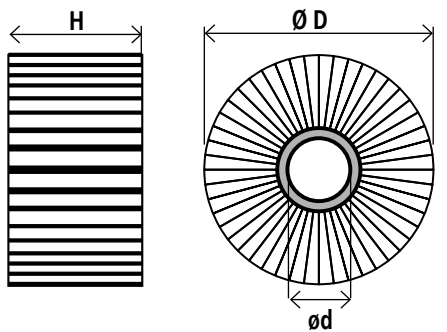

ABRASIVE FLAP WHEELS FOR BENCH GRINDERS



DIMENSIONS (mm)			ART. CODE	ART. CODE	ART. CODE	ART. CODE	ART. CODE	ART. CODE	
DIAM. (D)	THICK. (H)	BORE (d)	GRIT 40	GRIT 50	GRIT 60	GRIT 80	GRIT 100	GRIT 120	
100	30	26,00	G4511	G4512	G4513	G4514	G4515	G4611	10
100	50	26,00	G4521	G4522	G4523	G4524	G4525	G4621	10
165	30	54,00	G4541 •	G4542	G4543 •	G4544 •	G4545	G4641 •	10
165	50	54,00	G4551	G4552	G4553	G4554	G4555	G4651	10
200	30	54,00	G4561 •	G4562	G4563	G4564	G4565	G4661	10
200	50	54,00	G4571	G4572	G4573	G4574	G4575	G4671	10
250	30	100,00	G4581	G4582	G4583	G4584	G4585	G4681	10
250	50	100,00	G4591	G4592	G4593	G4594	G4595	G4691	10

DIMENSIONS (mm)			ART. CODE	ART. CODE	ART. CODE	ART. CODE	ART. CODE	
DIAM. (D)	THICK. (H)	BORE (d)	GRIT 150	GRIT 180	GRIT 220	GRIT 240	GRIT 320	
100	30	26,00	G4612	G4613	G4614	G4615	G4616	10
100	50	26,00	G4622	G4623	G4624	G4625	G4626	10
165	30	54,00	G4642	G4643 •	G4644	G4645	G4646	10
165	50	54,00	G4652	G4653	G4654	G4655	G4656	10
200	30	54,00	G4662	G4663	G4664	G4665	G4666	10
200	50	54,00	G4672	G4673	G4674	G4675	G4676	10
250	30	100,00	G4682	G4683	G4684	G4685	G4686	10
250	50	100,00	G4692	G4693	G4694	G4695	G4696	10

FLANGE COUPLES TO REDUCE THE BORE OF FLAP WHEELS

ART. CODE	DESCRIPTION
2300000000100	flange couple to reduce bore in diam. 25,40 mm wheels
2300000000165	flange couple to reduce bore in diam. 54,80 mm wheels
2300000000250	flange couple to reduce bore in diam. 100,00 mm wheels

Zirconia wheels are available with 18% price increase, minimum order quantity per type is of 30 pieces. Add suffix "Z" to the aluminum oxide article code.